

NX3L2467

Dual low-ohmic double-pole double-throw analog switch

Rev. 01 — 23 June 2009

Product data sheet

1. General description

The NX3L2467 is a dual low-ohmic double-pole double-throw analog switch suitable for use as an analog or digital multiplexer/demultiplexer. It consists of four switches, each with two independent input/outputs (nY0 and nY1) and a common input/output (nZ). The two digital inputs (1S and 2S) are used to select the switch position. 1S is used in selecting the independent inputs/outputs switched to 1Z and 2Z, and 2S is used in selecting the independent inputs/outputs switched to 3Z and 4Z. Schmitt trigger action at the select input (nS) makes the circuit tolerant to slower input rise and fall times across the entire V_{CC} range from 1.4 V to 4.3 V.

A low input voltage threshold allows pin nS to be driven by lower level logic signals without a significant increase in supply current I_{CC} . This makes it possible for the NX3L2467 to switch 4.3 V signals with a 1.8 V digital controller, eliminating the need for logic level translation. The NX3L2467 allows signals with amplitude up to V_{CC} to be transmitted from nZ to nY0 or nY1; or from nY0 or nY1 to nZ. Its low ON resistance (0.5 Ω) and flatness (0.13 Ω) ensures minimal attenuation and distortion of transmitted signals.

2. Features

- Wide supply voltage range from 1.4 V to 4.3 V
- Very low ON resistance (peak):
 - ◆ 1.7 Ω (typical) at $V_{CC} = 1.4$ V
 - ◆ 1.0 Ω (typical) at $V_{CC} = 1.65$ V
 - ◆ 0.6 Ω (typical) at $V_{CC} = 2.3$ V
 - ◆ 0.5 Ω (typical) at $V_{CC} = 2.7$ V
 - ◆ 0.5 Ω (typical) at $V_{CC} = 4.3$ V
- Break-before-make switching
- High noise immunity
- ESD protection:
 - ◆ HBM JESD22-A114E Class 3A exceeds 4000 V
 - ◆ MM JESD22-A115-A exceeds 200 V
 - ◆ CDM AEC-Q100-011 revision B exceeds 1000 V
- CMOS low-power consumption
- Latch-up performance exceeds 100 mA per JESD 78 Class II Level A
- 1.8 V control logic at $V_{CC} = 3.6$ V
- Control input accepts voltages above supply voltage
- Very low supply current, even when input is below V_{CC}
- High current handling capability (350 mA continuous current under 3.3 V supply)
- Specified from -40 °C to $+85$ °C and from -40 °C to $+125$ °C

3. Applications

- Cell phone
- PDA
- Portable media player

4. Ordering information

Table 1. Ordering information

Type number	Package			
	Temperature range	Name	Description	Version
NX3L2467HR	-40 °C to +125 °C	HXQFN16U	plastic thermal enhanced extremely thin quad flat package; no leads; 16 terminals; UTLP based; body 3 x 3 x 0.5 mm	SOT1039-1
NX3L2467PW	-40 °C to +125 °C	TSSOP16	plastic thin shrink small outline package; 16 leads; body width 4.4 mm	SOT403-1

5. Marking

Table 2. Marking codes

Type number	Marking code
NX3L2467HR	D67
NX3L2467PW	X3L2467

6. Functional diagram

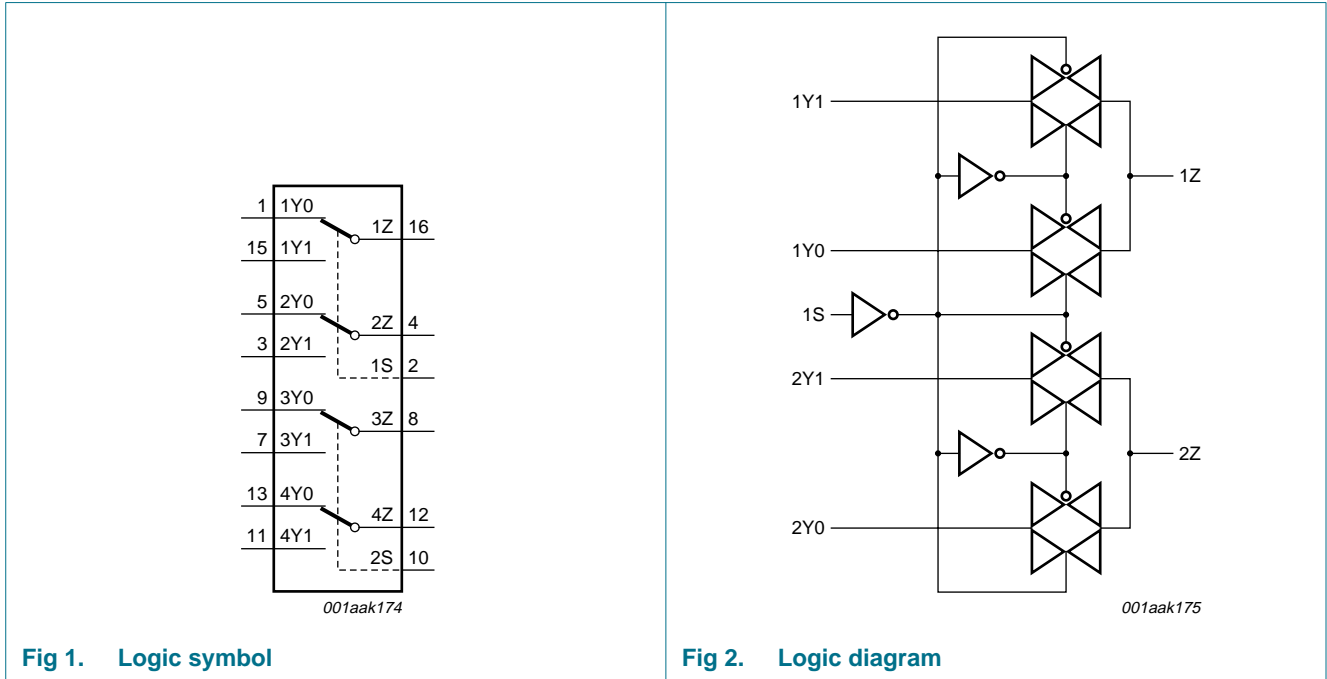

7. Pinning information

7.1 Pinning

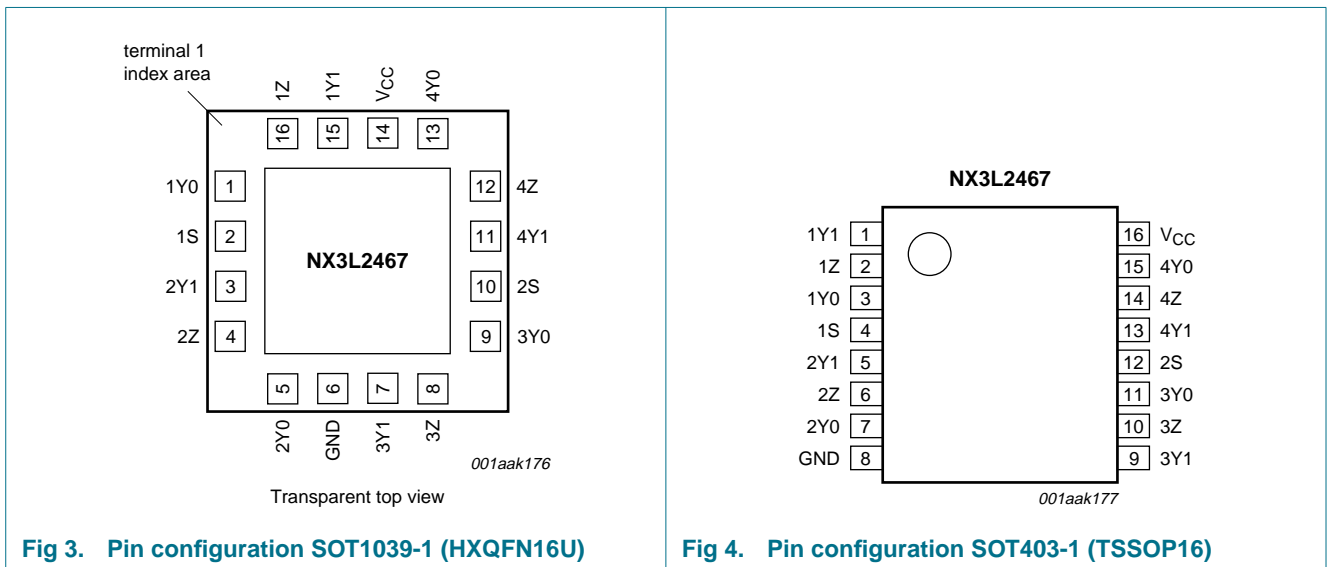

7.2 Pin description

Table 3. Pin description

Symbol	Pin		Description
	SOT1039-1	SOT403-1	
1Y0, 2Y0, 3Y0, 4Y0	1, 5, 9, 13	3, 7, 11, 15	independent input or output
1S, 2S	2, 10	4, 12	select input
1Y1, 2Y1, 3Y1, 4Y1	15, 3, 7, 11	1, 5, 9, 13	independent input or output
1Z, 2Z, 3Z, 4Z	16, 4, 8, 12	2, 6, 10, 14	common output or input
GND	6	8	ground (0 V)
V _{CC}	14	16	supply voltage

8. Functional description

Table 4. Function table^[1]

Input nS	Channel on
L	nY0
H	nY1

[1] H = HIGH voltage level; L = LOW voltage level.

9. Limiting values

Table 5. Limiting values

In accordance with the Absolute Maximum Rating System (IEC 60134). Voltages are referenced to GND (ground = 0 V).

Symbol	Parameter	Conditions	Min	Max	Unit
V _{CC}	supply voltage		-0.5	+4.6	V
V _I	input voltage	select input nS	[1] -0.5	+4.6	V
V _{SW}	switch voltage		[2] -0.5	V _{CC} + 0.5	V
I _{IK}	input clamping current	V _I < -0.5 V	-50	-	mA
I _{SK}	switch clamping current	V _I < -0.5 V or V _I > V _{CC} + 0.5 V	-	±50	mA
I _{SW}	switch current	V _{SW} > -0.5 V or V _{SW} < V _{CC} + 0.5 V; source or sink current	-	±350	mA
		V _{SW} > -0.5 V or V _{SW} < V _{CC} + 0.5 V; pulsed at 1 ms duration, < 10 % duty cycle; peak current	-	±500	mA
T _{stg}	storage temperature		-65	+150	°C
P _{tot}	total power dissipation	T _{amb} = -40 °C to +125 °C			
		HXQFN16U	[3] -	250	mW
		TSSOP16	[4] -	500	mW

[1] The minimum input voltage rating may be exceeded if the input current rating is observed.

[2] The minimum and maximum switch voltage ratings may be exceeded if the switch clamping current rating is observed but may not exceed 4.6 V.

[3] For HXQFN16U package: above 135 °C the value of P_{tot} derates linearly with 16.9 mW/K.

[4] For TSSOP16 package: above 60 °C the value of P_{tot} derates linearly with 5.5 mW/K above.

10. Recommended operating conditions

Table 6. Recommended operating conditions

Symbol	Parameter	Conditions	Min	Max	Unit
V_{CC}	supply voltage		1.4	4.3	V
V_I	input voltage	select input nS	0	4.3	V
V_{SW}	switch voltage		[1] 0	V_{CC}	V
T_{amb}	ambient temperature		-40	+125	°C
$\Delta t/\Delta V$	input transition rise and fall rate	$V_{CC} = 1.4\text{ V to }4.3\text{ V}$	[2] -	200	ns/V

[1] To avoid sinking GND current from terminal nZ when switch current flows in terminal nYn, the voltage drop across the bidirectional switch must not exceed 0.4 V. If the switch current flows into terminal nZ, no GND current will flow from terminal nYn. In this case, there is no limit for the voltage drop across the switch.

[2] Applies to control signal levels.

11. Static characteristics

Table 7. Static characteristics

At recommended operating conditions; voltages are referenced to GND (ground 0 V).

Symbol	Parameter	Conditions	$T_{amb} = 25\text{ °C}$			$T_{amb} = -40\text{ °C to }+125\text{ °C}$			Unit
			Min	Typ	Max	Min	Max (85 °C)	Max (125 °C)	
V_{IH}	HIGH-level input voltage	$V_{CC} = 1.4\text{ V to }1.6\text{ V}$	0.9	-	-	0.9	-	-	V
		$V_{CC} = 1.65\text{ V to }1.95\text{ V}$	0.9	-	-	0.9	-	-	V
		$V_{CC} = 2.3\text{ V to }2.7\text{ V}$	1.1	-	-	1.1	-	-	V
		$V_{CC} = 2.7\text{ V to }3.6\text{ V}$	1.3	-	-	1.3	-	-	V
		$V_{CC} = 3.6\text{ V to }4.3\text{ V}$	1.4	-	-	1.4	-	-	V
V_{IL}	LOW-level input voltage	$V_{CC} = 1.4\text{ V to }1.6\text{ V}$	-	-	0.3	-	0.3	0.3	V
		$V_{CC} = 1.65\text{ V to }1.95\text{ V}$	-	-	0.4	-	0.4	0.3	V
		$V_{CC} = 2.3\text{ V to }2.7\text{ V}$	-	-	0.4	-	0.4	0.4	V
		$V_{CC} = 2.7\text{ V to }3.6\text{ V}$	-	-	0.5	-	0.5	0.5	V
		$V_{CC} = 3.6\text{ V to }4.3\text{ V}$	-	-	0.6	-	0.6	0.6	V
I_I	input leakage current	select input nS; $V_I = \text{GND to }4.3\text{ V};$ $V_{CC} = 1.4\text{ V to }4.3\text{ V}$	-	-	-	-	± 0.5	± 1	μA
$I_{S(OFF)}$	OFF-state leakage current	nY0 and nY1 port; see Figure 5							
		$V_{CC} = 1.4\text{ V to }3.6\text{ V}$	-	-	± 5	-	± 50	± 500	nA
		$V_{CC} = 3.6\text{ V to }4.3\text{ V}$	-	-	± 10	-	± 50	± 500	nA
$I_{S(ON)}$	ON-state leakage current	nZ port; $V_{CC} = 1.4\text{ V to }3.6\text{ V};$ see Figure 6							
		$V_{CC} = 1.4\text{ V to }3.6\text{ V}$	-	-	± 5	-	± 50	± 500	nA
		$V_{CC} = 3.6\text{ V to }4.3\text{ V}$	-	-	± 10	-	± 50	± 500	nA

Table 7. Static characteristics ...continued
 At recommended operating conditions; voltages are referenced to GND (ground 0 V).

Symbol	Parameter	Conditions	T _{amb} = 25 °C			T _{amb} = -40 °C to +125 °C			Unit
			Min	Typ	Max	Min	Max (85 °C)	Max (125 °C)	
I _{CC}	supply current	V _I = V _{CC} or GND; V _{SW} = GND or V _{CC}							
		V _{CC} = 3.6 V	-	-	100	-	500	5000	nA
		V _{CC} = 4.3 V	-	-	150	-	800	6000	nA
ΔI _{CC}	additional supply current	V _{SW} = GND or V _{CC}							
		V _I = 2.6 V; V _{CC} = 4.3 V	-	2.0	4.0	-	7	7	μA
		V _I = 2.6 V; V _{CC} = 3.6 V	-	0.35	0.7	-	1	1	μA
		V _I = 1.8 V; V _{CC} = 4.3 V	-	7.0	10.0	-	15	15	μA
		V _I = 1.8 V; V _{CC} = 3.6 V	-	2.5	4.0	-	5	5	μA
		V _I = 1.8 V; V _{CC} = 2.5 V	-	50	200	-	300	500	nA
C _I	input capacitance		-	1.0	-	-	-	-	pF
C _{S(OFF)}	OFF-state capacitance		-	35	-	-	-	-	pF
C _{S(ON)}	ON-state capacitance		-	130	-	-	-	-	pF

11.1 Test circuits

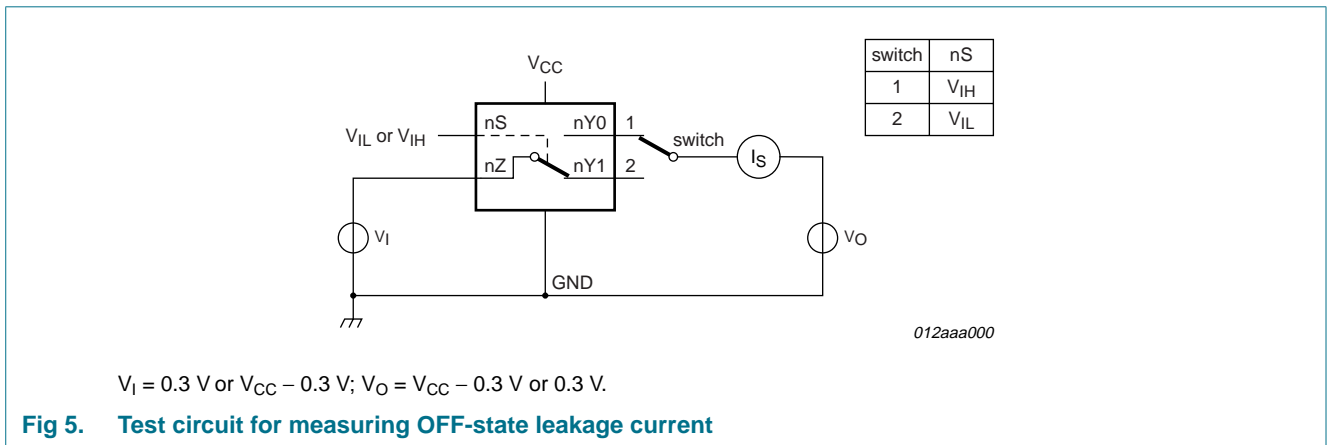

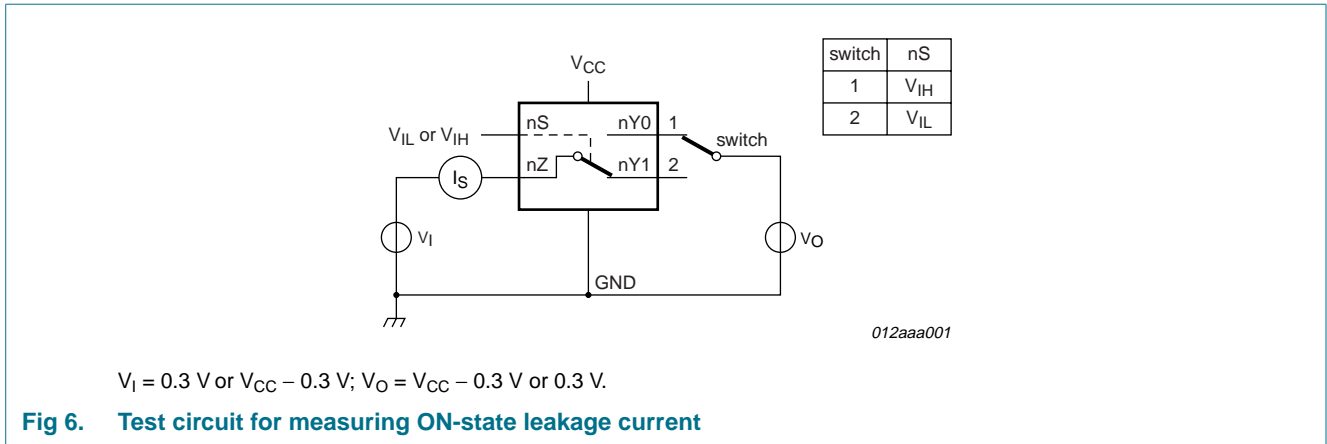

11.2 ON resistance

Table 8. ON resistance^[1]

At recommended operating conditions; voltages are referenced to GND (ground = 0 V); for graphs see [Figure 8](#) to [Figure 14](#).

Symbol	Parameter	Conditions	T _{amb} = -40 °C to +85 °C			T _{amb} = -40 °C to +125 °C		Unit	
			Min	Typ ^[2]	Max	Min	Max		
R _{ON(peak)}	ON resistance (peak)	V _I = GND to V _{CC} ; I _{SW} = 100 mA; see Figure 7							
			V _{CC} = 1.4 V	-	1.7	3.7	-	4.1	Ω
			V _{CC} = 1.65 V	-	1.0	1.6	-	1.7	Ω
			V _{CC} = 2.3 V	-	0.6	0.8	-	0.9	Ω
			V _{CC} = 2.7 V	-	0.5	0.75	-	0.9	Ω
			V _{CC} = 4.3 V	-	0.5	0.75	-	0.9	Ω
ΔR _{ON}	ON resistance mismatch between channels	V _I = GND to V _{CC} ; I _{SW} = 100 mA ^[3]							
			V _{CC} = 1.4 V; V _{SW} = 0.4 V	-	0.18	0.3	-	0.3	Ω
			V _{CC} = 1.65 V; V _{SW} = 0.5 V	-	0.18	0.2	-	0.3	Ω
			V _{CC} = 2.3 V; V _{SW} = 0.7 V	-	0.07	0.1	-	0.13	Ω
			V _{CC} = 2.7 V; V _{SW} = 0.8 V	-	0.07	0.1	-	0.13	Ω
			V _{CC} = 4.3 V; V _{SW} = 0.8 V	-	0.07	0.1	-	0.13	Ω
R _{ON(flat)}	ON resistance (flatness)	V _I = GND to V _{CC} ; I _{SW} = 100 mA ^[4]							
			V _{CC} = 1.4 V	-	1.0	3.3	-	3.6	Ω
			V _{CC} = 1.65 V	-	0.5	1.2	-	1.3	Ω
			V _{CC} = 2.3 V	-	0.15	0.3	-	0.35	Ω
			V _{CC} = 2.7 V	-	0.13	0.3	-	0.35	Ω
			V _{CC} = 4.3 V	-	0.2	0.4	-	0.45	Ω

[1] For NX3L2467PW (TSSOP16 package), all ON resistance values are up to 0.05 Ω higher.

[2] Typical values are measured at T_{amb} = 25 °C.

[3] Measured at identical V_{CC}, temperature and input voltage.

[4] Flatness is defined as the difference between the maximum and minimum value of ON resistance measured at identical V_{CC} and temperature.

11.3 ON resistance test circuit and graphs

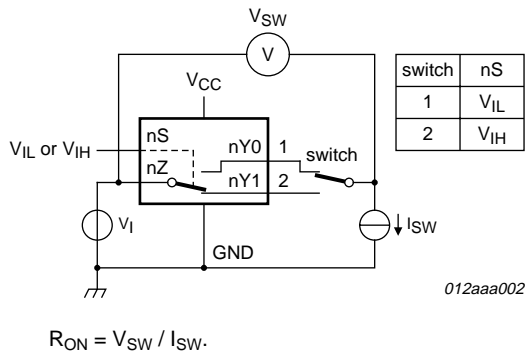
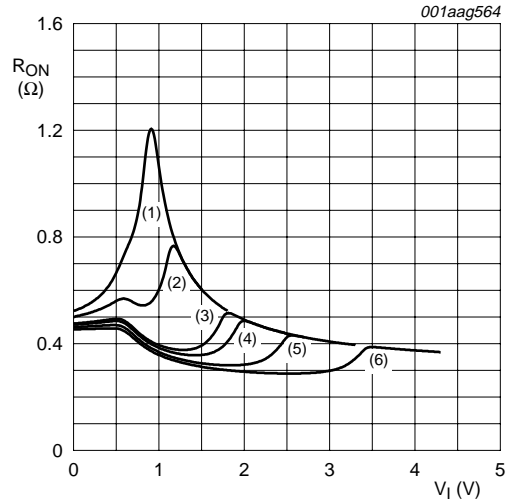

Fig 7. Test circuit for measuring ON resistance



- (1) V_{CC} = 1.5 V.
- (2) V_{CC} = 1.8 V.
- (3) V_{CC} = 2.5 V.
- (4) V_{CC} = 2.7 V.
- (5) V_{CC} = 3.3 V.
- (6) V_{CC} = 4.3 V.

Measured at T_{amb} = 25 °C.

Fig 8. Typical ON resistance as a function of input voltage

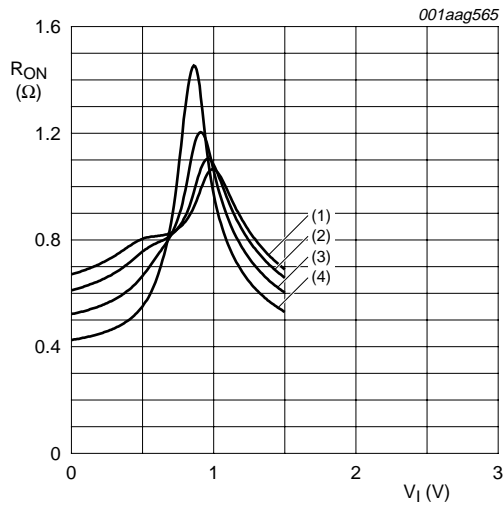

- (1) $T_{amb} = 125\text{ }^{\circ}\text{C}.$
- (2) $T_{amb} = 85\text{ }^{\circ}\text{C}.$
- (3) $T_{amb} = 25\text{ }^{\circ}\text{C}.$
- (4) $T_{amb} = -40\text{ }^{\circ}\text{C}.$

Fig 9. ON resistance as a function of input voltage;
 $V_{CC} = 1.5\text{ V}$

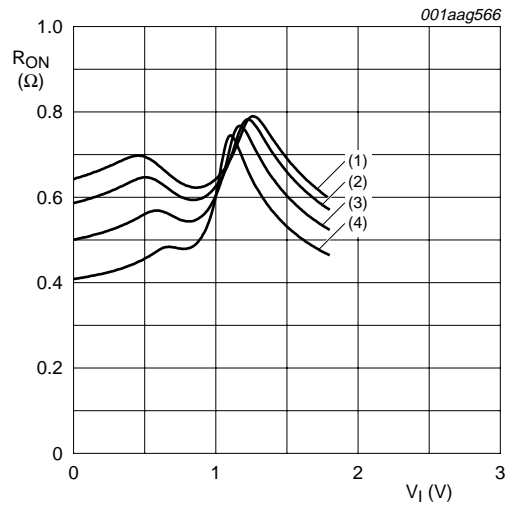

- (1) $T_{amb} = 125\text{ }^{\circ}\text{C}.$
- (2) $T_{amb} = 85\text{ }^{\circ}\text{C}.$
- (3) $T_{amb} = 25\text{ }^{\circ}\text{C}.$
- (4) $T_{amb} = -40\text{ }^{\circ}\text{C}.$

Fig 10. ON resistance as a function of input voltage;
 $V_{CC} = 1.8\text{ V}$

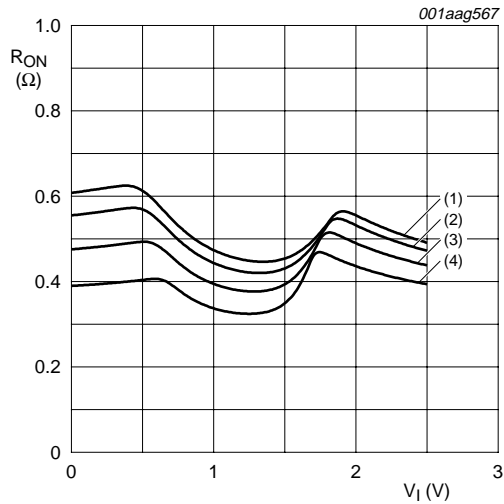

- (1) $T_{amb} = 125\text{ }^{\circ}\text{C}.$
- (2) $T_{amb} = 85\text{ }^{\circ}\text{C}.$
- (3) $T_{amb} = 25\text{ }^{\circ}\text{C}.$
- (4) $T_{amb} = -40\text{ }^{\circ}\text{C}.$

Fig 11. ON resistance as a function of input voltage;
 $V_{CC} = 2.5\text{ V}$

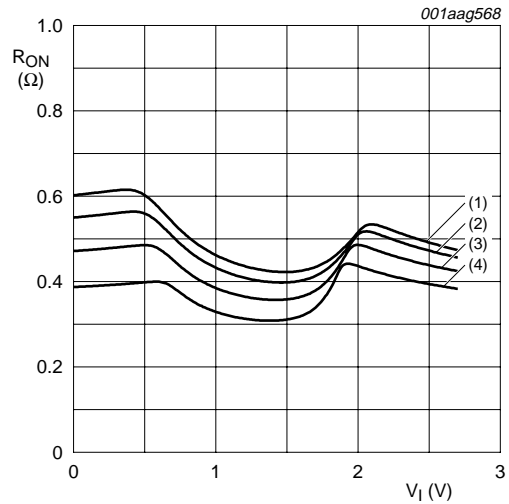

- (1) $T_{amb} = 125\text{ }^{\circ}\text{C}.$
- (2) $T_{amb} = 85\text{ }^{\circ}\text{C}.$
- (3) $T_{amb} = 25\text{ }^{\circ}\text{C}.$
- (4) $T_{amb} = -40\text{ }^{\circ}\text{C}.$

Fig 12. ON resistance as a function of input voltage;
 $V_{CC} = 2.7\text{ V}$

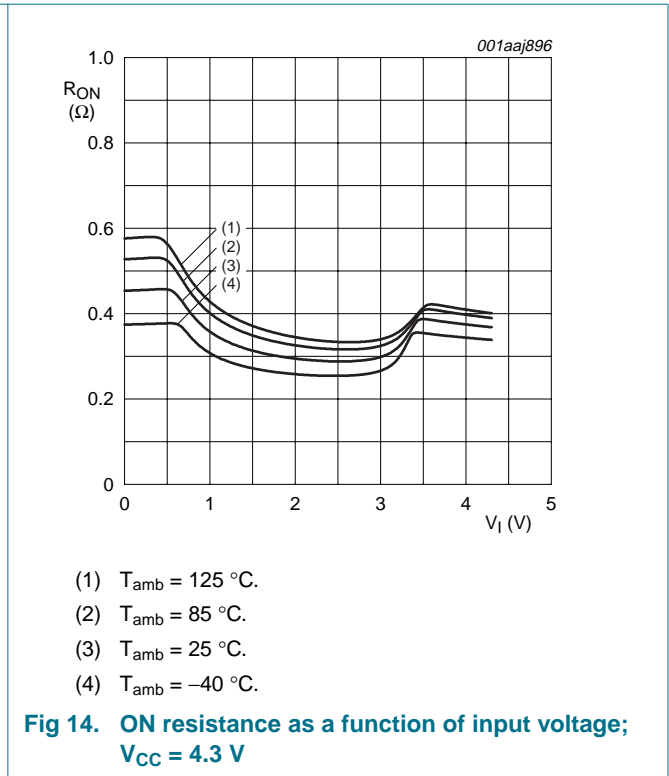
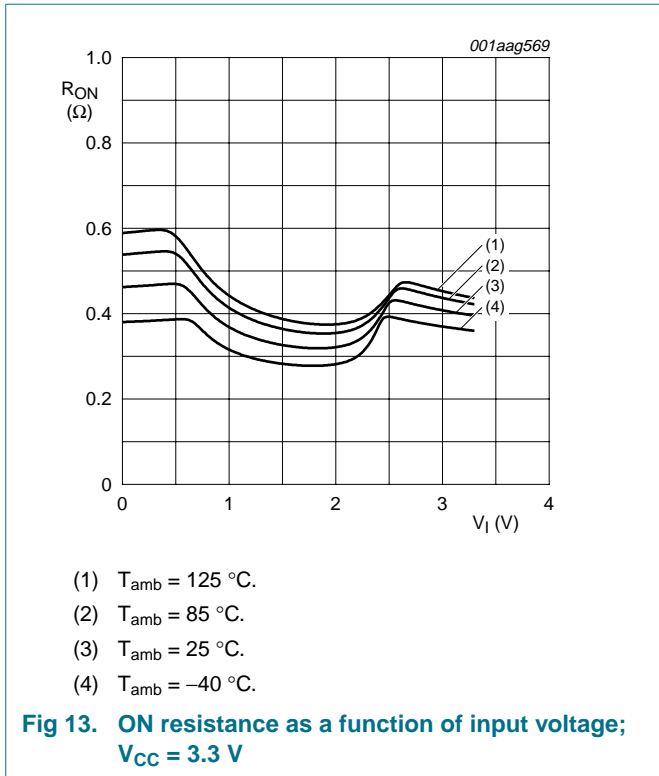

12. Dynamic characteristics

Table 9. Dynamic characteristics

At recommended operating conditions; voltages are referenced to GND (ground = 0 V); for load circuit see [Figure 17](#).

Symbol	Parameter	Conditions	25 °C			-40 °C to +125 °C			Unit
			Min	Typ ^[1]	Max	Min	Max (85 °C)	Max (125 °C)	
t_{en}	enable time	nS to nZ or nYn; see Figure 15							
		$V_{CC} = 1.4\text{ V to }1.6\text{ V}$	-	41	90	-	120	120	ns
		$V_{CC} = 1.65\text{ V to }1.95\text{ V}$	-	30	70	-	80	90	ns
		$V_{CC} = 2.3\text{ V to }2.7\text{ V}$	-	20	45	-	50	55	ns
		$V_{CC} = 2.7\text{ V to }3.6\text{ V}$	-	19	40	-	45	50	ns
		$V_{CC} = 3.6\text{ V to }4.3\text{ V}$	-	19	40	-	45	50	ns
t_{dis}	disable time	nS to nZ or nYn; see Figure 15							
		$V_{CC} = 1.4\text{ V to }1.6\text{ V}$	-	24	70	-	80	90	ns
		$V_{CC} = 1.65\text{ V to }1.95\text{ V}$	-	15	55	-	60	65	ns
		$V_{CC} = 2.3\text{ V to }2.7\text{ V}$	-	9	25	-	30	35	ns
		$V_{CC} = 2.7\text{ V to }3.6\text{ V}$	-	8	20	-	25	30	ns
		$V_{CC} = 3.6\text{ V to }4.3\text{ V}$	-	8	20	-	25	30	ns

Dual low-ohmic double-pole double-throw analog switch

Table 9. Dynamic characteristics ...continued

At recommended operating conditions; voltages are referenced to GND (ground = 0 V); for load circuit see [Figure 17](#).

Symbol	Parameter	Conditions	25 °C			-40 °C to +125 °C			Unit	
			Min	Typ ^[1]	Max	Min	Max (85 °C)	Max (125 °C)		
t _{b-m}	break-before-make time	see Figure 16								
			V _{CC} = 1.4 V to 1.6 V	-	20	-	9	-	-	ns
			V _{CC} = 1.65 V to 1.95 V	-	17	-	7	-	-	ns
			V _{CC} = 2.3 V to 2.7 V	-	13	-	4	-	-	ns
			V _{CC} = 2.7 V to 3.6 V	-	11	-	3	-	-	ns
	V _{CC} = 3.6 V to 4.3 V	-	11	-	2	-	-	ns		

[1] Typical values are measured at T_{amb} = 25 °C and V_{CC} = 1.5 V, 1.8 V, 2.5 V, 3.3 V and 4.3 V respectively.

[2] Break-before-make guaranteed by design.

12.1 Waveform and test circuits

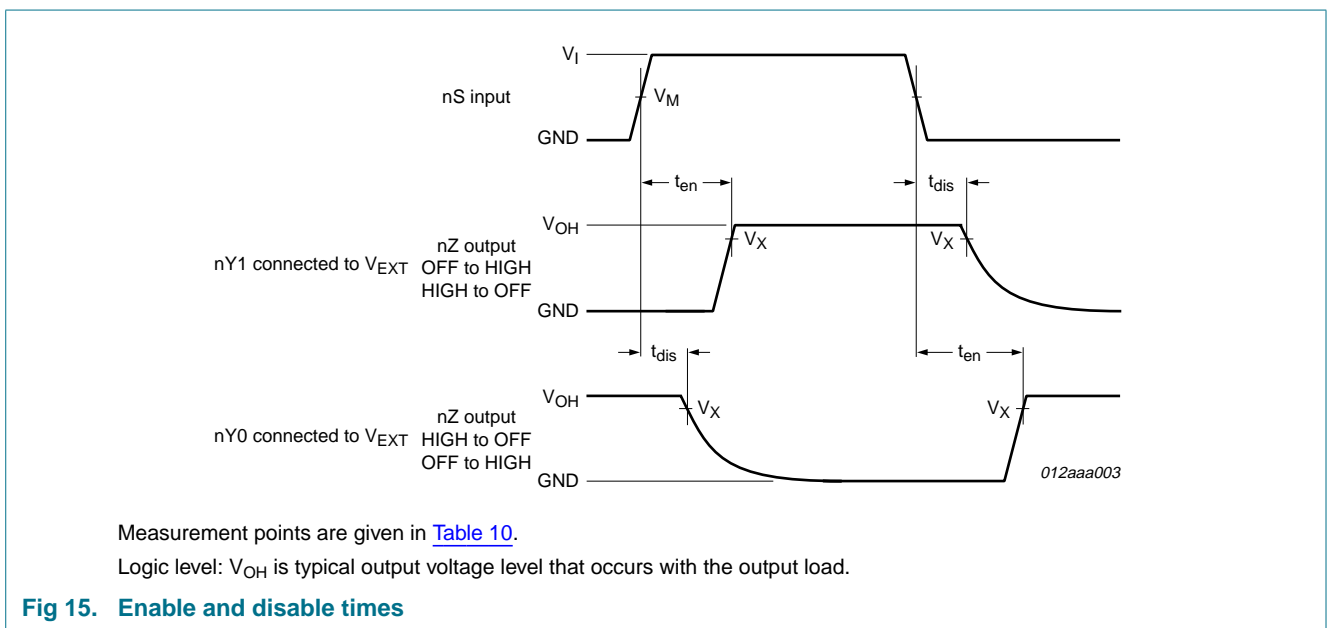

Table 10. Measurement points

Supply voltage	Input	Output
V _{CC}	V _M	V _X
1.4 V to 4.3 V	0.5V _{CC}	0.9V _{OH}

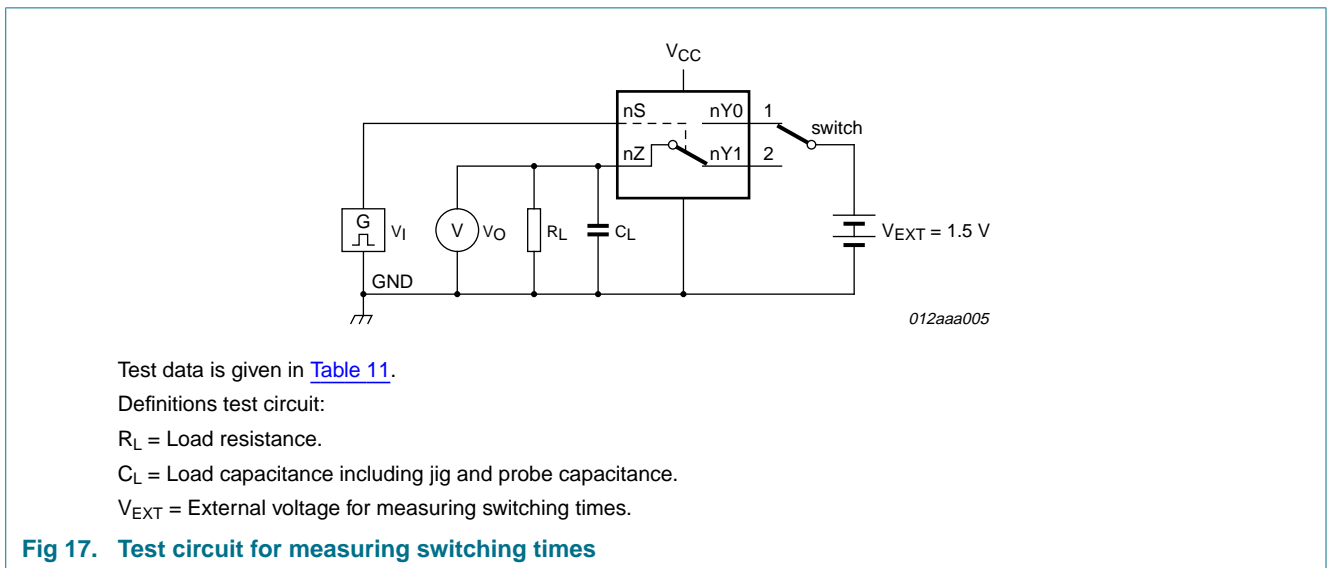
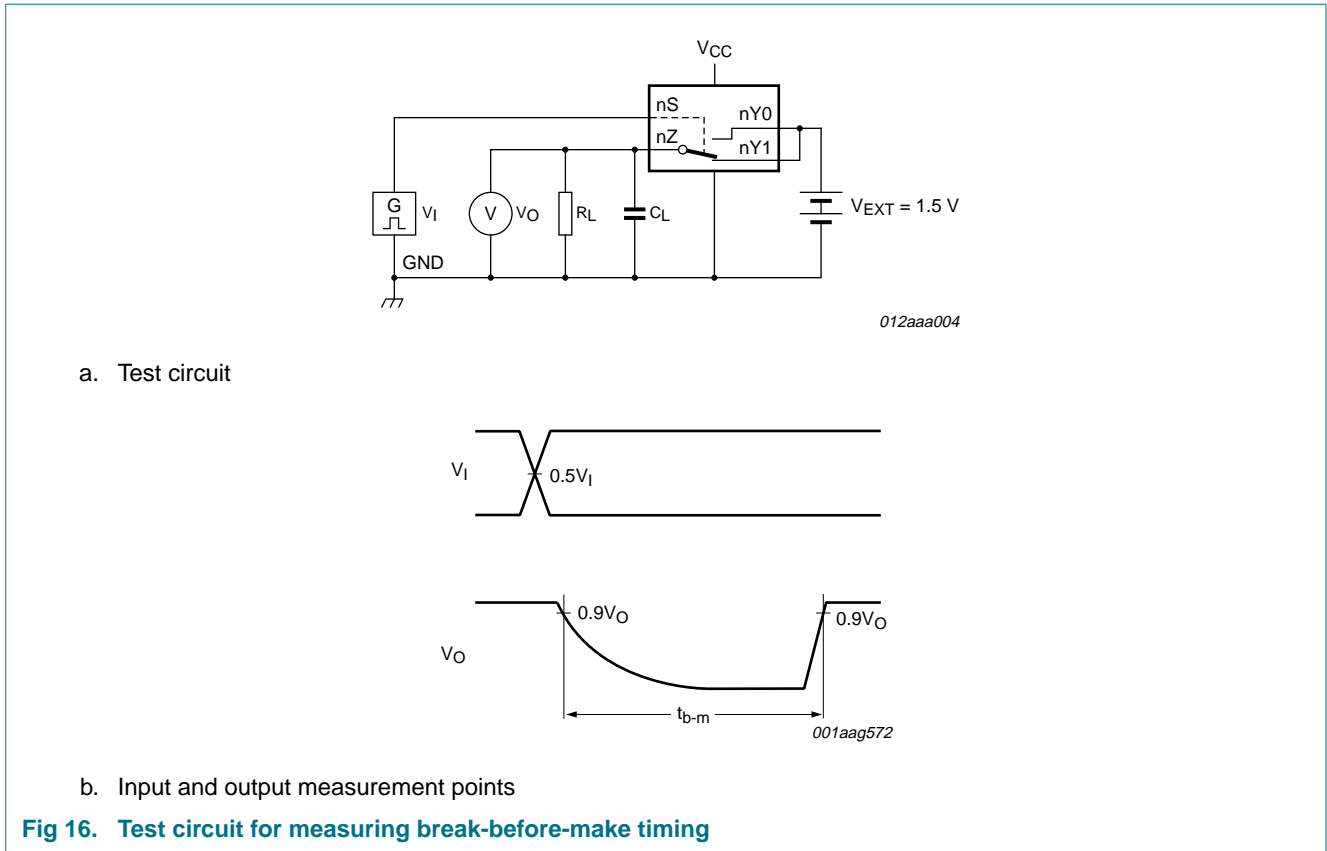

Table 11. Test data

Supply voltage	Input		Load	
V_{CC}	V_I	t_r, t_f	C_L	R_L
1.4 V to 4.3 V	V_{CC}	≤ 2.5 ns	35 pF	50 Ω

12.2 Additional dynamic characteristics

Table 12. Additional dynamic characteristics

At recommended operating conditions; voltages are referenced to GND (ground = 0 V); $V_I = GND$ or V_{CC} (unless otherwise specified); $t_r = t_f \leq 2.5$ ns; $T_{amb} = 25$ °C.

Symbol	Parameter	Conditions	Min	Typ	Max	Unit
THD	total harmonic distortion	$f_i = 20$ Hz to 20 kHz; $R_L = 32$ Ω ; see Figure 18	[1]			
		$V_{CC} = 1.4$ V; $V_I = 1$ V (p-p)	-	0.15	-	%
		$V_{CC} = 1.65$ V; $V_I = 1.2$ V (p-p)	-	0.10	-	%
		$V_{CC} = 2.3$ V; $V_I = 1.5$ V (p-p)	-	0.02	-	%
		$V_{CC} = 2.7$ V; $V_I = 2$ V (p-p)	-	0.02	-	%
		$V_{CC} = 4.3$ V; $V_I = 2$ V (p-p)	-	0.02	-	%
$f_{(-3dB)}$	-3 dB frequency response	$R_L = 50$ Ω ; see Figure 19	[1]			
		$V_{CC} = 1.4$ V to 4.3 V	-	60	-	MHz
α_{iso}	isolation (OFF-state)	$f_i = 100$ kHz; $R_L = 50$ Ω ; see Figure 20	[1]			
		$V_{CC} = 1.4$ V to 4.3 V	-	-90	-	dB
V_{ct}	crosstalk voltage	between digital inputs and switch;				
		$f_i = 1$ MHz; $C_L = 50$ pF; $R_L = 50$ Ω ; see Figure 21				
		$V_{CC} = 1.4$ V to 3.6 V	-	0.2	-	V
		$V_{CC} = 3.6$ V to 4.3 V	-	0.3	-	V
Xtalk	crosstalk	between switches;	[1]			
		$f_i = 100$ kHz; $R_L = 50$ Ω ; see Figure 22				
		$V_{CC} = 1.4$ V to 4.3 V	-	-90	-	dB
Q_{inj}	charge injection	$f_i = 1$ MHz; $C_L = 0.1$ nF; $R_L = 1$ M Ω ; $V_{gen} = 0$ V; $R_{gen} = 0$ Ω ; see Figure 23				
		$V_{CC} = 1.5$ V	-	3	-	pC
		$V_{CC} = 1.8$ V	-	4	-	pC
		$V_{CC} = 2.5$ V	-	6	-	pC
		$V_{CC} = 3.3$ V	-	9	-	pC
		$V_{CC} = 4.3$ V	-	15	-	pC

[1] f_i is biased at $0.5V_{CC}$.

12.3 Test circuits

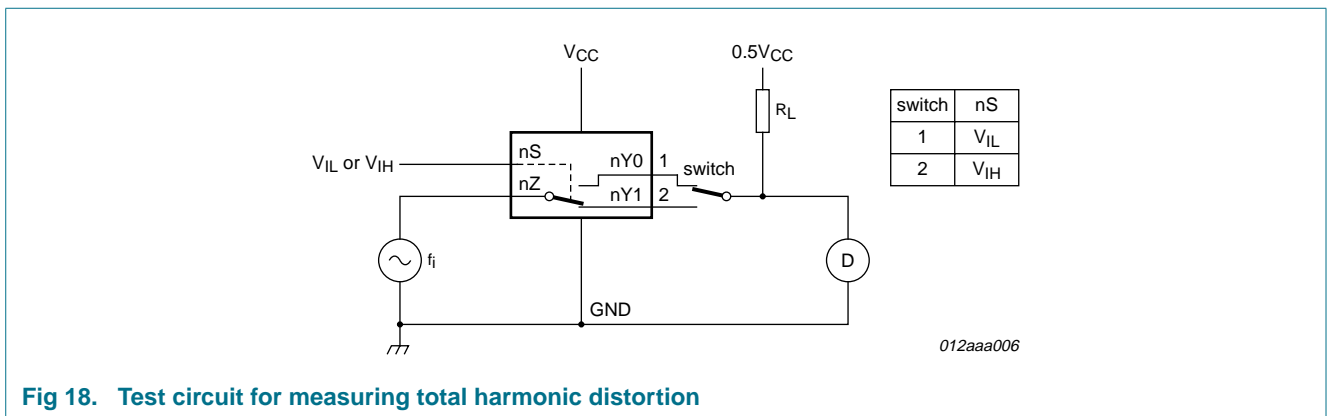
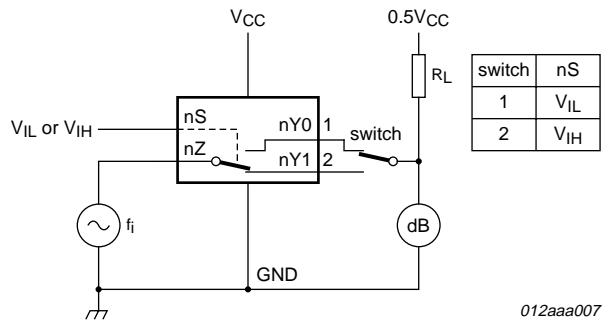

Fig 18. Test circuit for measuring total harmonic distortion

Dual low-ohmic double-pole double-throw analog switch



012aaa007

Adjust f_i voltage to obtain 0 dBm level at output. Increase f_i frequency until dB meter reads -3 dB.

Fig 19. Test circuit for measuring the frequency response when channel is in ON-state

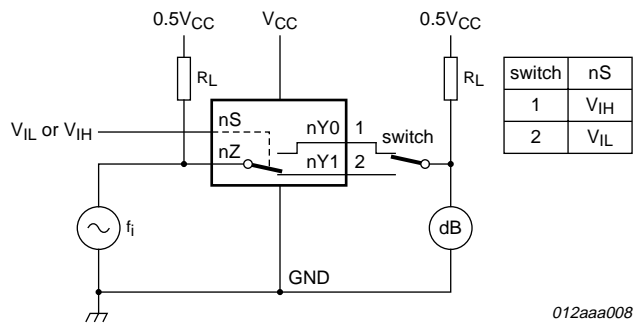

012aaa008

Adjust f_i voltage to obtain 0 dBm level at input.

Fig 20. Test circuit for measuring isolation (OFF-state)

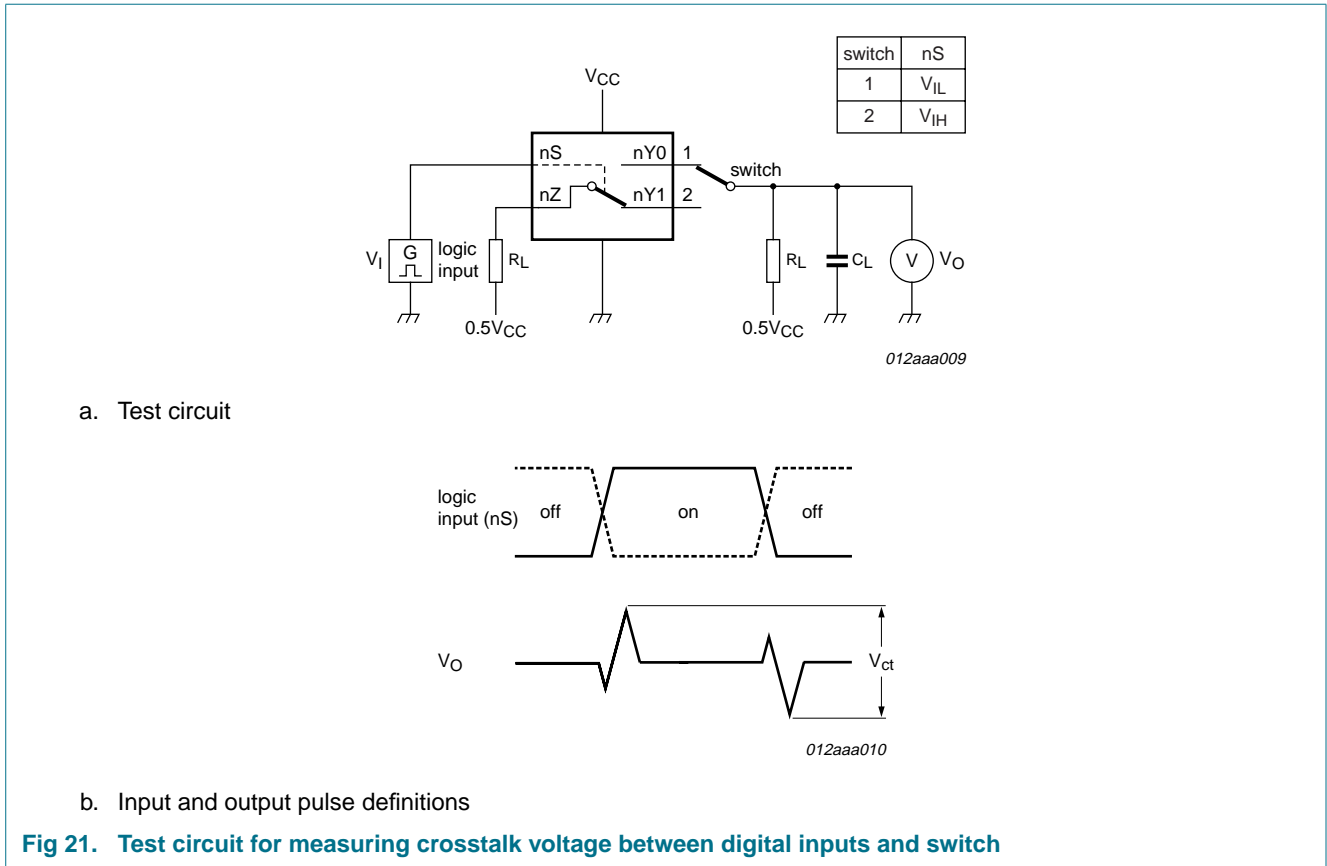

Fig 21. Test circuit for measuring crosstalk voltage between digital inputs and switch

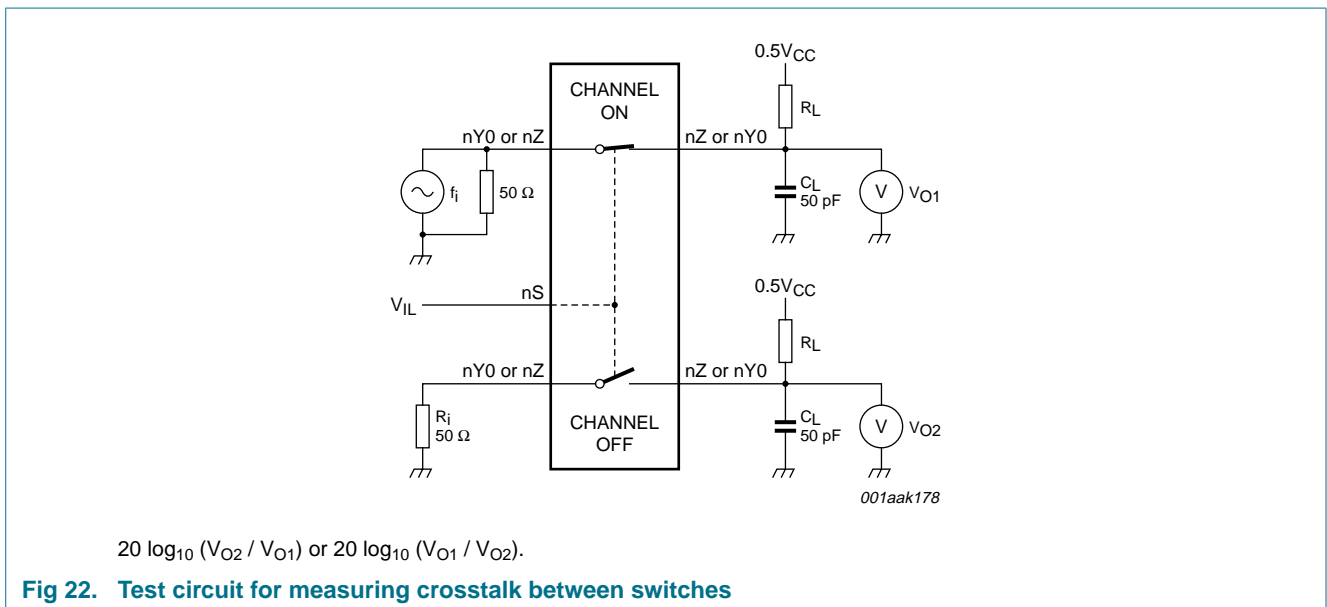
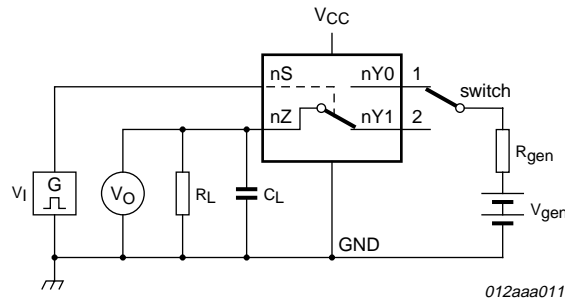
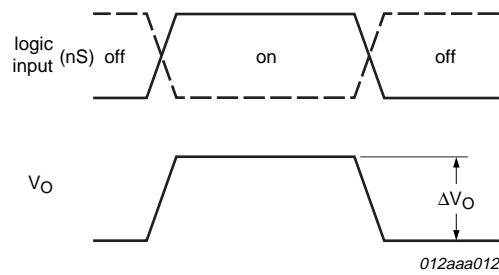

Fig 22. Test circuit for measuring crosstalk between switches



a. Test circuit



b. Input and output pulse definitions

Definition: $Q_{inj} = \Delta V_O \times C_L$.

ΔV_O = output voltage variation.

R_{gen} = generator resistance.

V_{gen} = generator voltage.

Fig 23. Test circuit for measuring charge injection

13. Package outline

HXQFN16U: plastic thermal enhanced extremely thin quad flat package; no leads;
16 terminals; UTLP based; body 3 x 3 x 0.5 mm

SOT1039-1

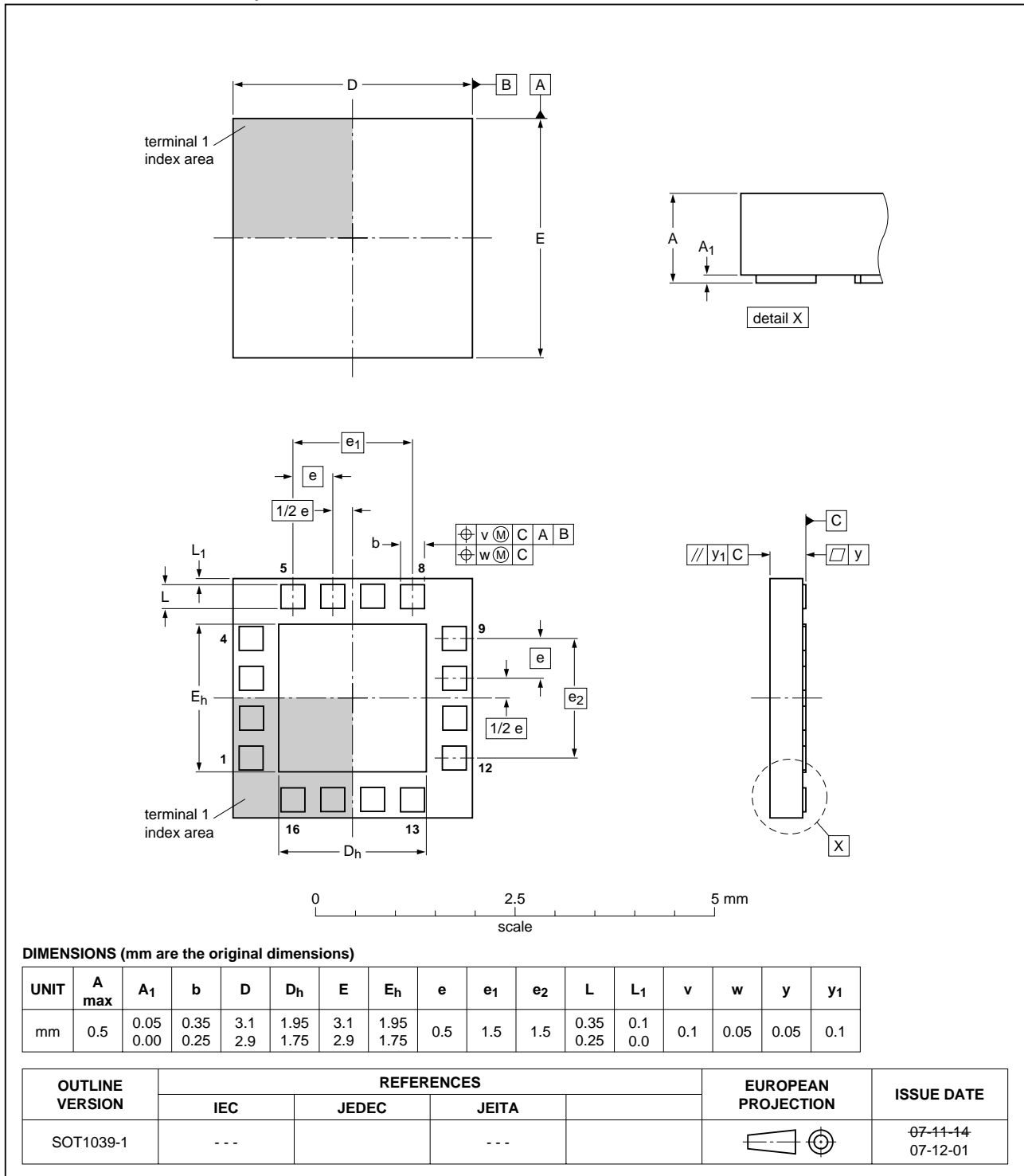

Fig 24. Package outline SOT1039-1 (HXQFN16U)

TSSOP16: plastic thin shrink small outline package; 16 leads; body width 4.4 mm

SOT403-1

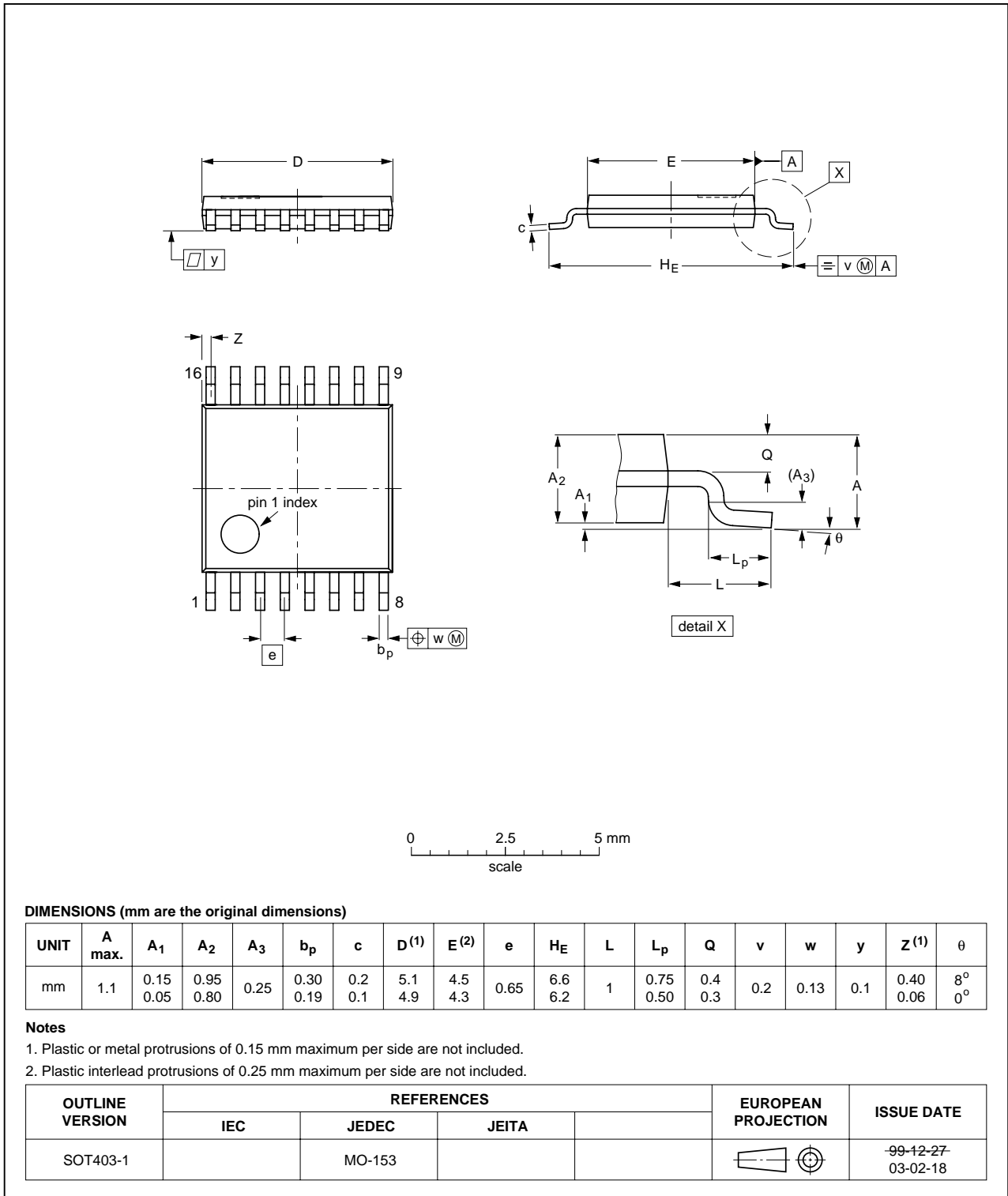

Fig 25. Package outline SOT403-1 (TSSOP16)

14. Abbreviations

Table 13. Abbreviations

Acronym	Description
CDM	Charged Device Model
CMOS	Complementary Metal-Oxide Semiconductor
ESD	ElectroStatic Discharge
HBM	Human Body Model
MM	Machine Model
PDA	Personal Digital Assistant
TTL	Transistor-Transistor Logic

15. Revision history

Table 14. Revision history

Document ID	Release date	Data sheet status	Change notice	Supersedes
NX3L2467_1	20090623	Product data sheet	-	-

16. Legal information

16.1 Data sheet status

Document status ^{[1][2]}	Product status ^[3]	Definition
Objective [short] data sheet	Development	This document contains data from the objective specification for product development.
Preliminary [short] data sheet	Qualification	This document contains data from the preliminary specification.
Product [short] data sheet	Production	This document contains the product specification.

[1] Please consult the most recently issued document before initiating or completing a design.

[2] The term 'short data sheet' is explained in section "Definitions".

[3] The product status of device(s) described in this document may have changed since this document was published and may differ in case of multiple devices. The latest product status information is available on the Internet at URL <http://www.nxp.com>.

16.2 Definitions

Draft — The document is a draft version only. The content is still under internal review and subject to formal approval, which may result in modifications or additions. NXP Semiconductors does not give any representations or warranties as to the accuracy or completeness of information included herein and shall have no liability for the consequences of use of such information.

Short data sheet — A short data sheet is an extract from a full data sheet with the same product type number(s) and title. A short data sheet is intended for quick reference only and should not be relied upon to contain detailed and full information. For detailed and full information see the relevant full data sheet, which is available on request via the local NXP Semiconductors sales office. In case of any inconsistency or conflict with the short data sheet, the full data sheet shall prevail.

16.3 Disclaimers

General — Information in this document is believed to be accurate and reliable. However, NXP Semiconductors does not give any representations or warranties, expressed or implied, as to the accuracy or completeness of such information and shall have no liability for the consequences of use of such information.

Right to make changes — NXP Semiconductors reserves the right to make changes to information published in this document, including without limitation specifications and product descriptions, at any time and without notice. This document supersedes and replaces all information supplied prior to the publication hereof.

Suitability for use — NXP Semiconductors products are not designed, authorized or warranted to be suitable for use in medical, military, aircraft, space or life support equipment, nor in applications where failure or malfunction of an NXP Semiconductors product can reasonably be expected to result in personal injury, death or severe property or environmental

damage. NXP Semiconductors accepts no liability for inclusion and/or use of NXP Semiconductors products in such equipment or applications and therefore such inclusion and/or use is at the customer's own risk.

Applications — Applications that are described herein for any of these products are for illustrative purposes only. NXP Semiconductors makes no representation or warranty that such applications will be suitable for the specified use without further testing or modification.

Limiting values — Stress above one or more limiting values (as defined in the Absolute Maximum Ratings System of IEC 60134) may cause permanent damage to the device. Limiting values are stress ratings only and operation of the device at these or any other conditions above those given in the Characteristics sections of this document is not implied. Exposure to limiting values for extended periods may affect device reliability.

Terms and conditions of sale — NXP Semiconductors products are sold subject to the general terms and conditions of commercial sale, as published at <http://www.nxp.com/profile/terms>, including those pertaining to warranty, intellectual property rights infringement and limitation of liability, unless explicitly otherwise agreed to in writing by NXP Semiconductors. In case of any inconsistency or conflict between information in this document and such terms and conditions, the latter will prevail.

No offer to sell or license — Nothing in this document may be interpreted or construed as an offer to sell products that is open for acceptance or the grant, conveyance or implication of any license under any copyrights, patents or other industrial or intellectual property rights.

Export control — This document as well as the item(s) described herein may be subject to export control regulations. Export might require a prior authorization from national authorities.

16.4 Trademarks

Notice: All referenced brands, product names, service names and trademarks are the property of their respective owners.

17. Contact information

For more information, please visit: <http://www.nxp.com>

For sales office addresses, please send an email to: salesaddresses@nxp.com

18. Contents

1 General description 1

2 Features 1

3 Applications 2

4 Ordering information 2

5 Marking 2

6 Functional diagram 3

7 Pinning information 3

7.1 Pinning 3

7.2 Pin description 4

8 Functional description 4

9 Limiting values 4

10 Recommended operating conditions 5

11 Static characteristics 5

11.1 Test circuits 6

11.2 ON resistance 7

11.3 ON resistance test circuit and graphs 8

12 Dynamic characteristics 10

12.1 Waveform and test circuits 11

12.2 Additional dynamic characteristics 13

12.3 Test circuits 13

13 Package outline 17

14 Abbreviations 19

15 Revision history 19

16 Legal information 20

16.1 Data sheet status 20

16.2 Definitions 20

16.3 Disclaimers 20

16.4 Trademarks 20

17 Contact information 20

18 Contents 21

Please be aware that important notices concerning this document and the product(s) described herein, have been included in section 'Legal information'.



© NXP B.V. 2009. **All rights reserved.**
 For more information, please visit: <http://www.nxp.com>
 For sales office addresses, please send an email to: salesaddresses@nxp.com
 Date of release: 23 June 2009
 Document identifier: NX3L2467_1